

## Hinge Terminology Guide

Selecting the correct hinge can be a bit overwhelming, especially given the varieties of mounting types and styles. Those of us that do not deal with hinges on a daily basis can find the selection process a bit confusing. This brief guide has been designed to help explain some of the basic terminology, and help “open the door” for a proper selection.

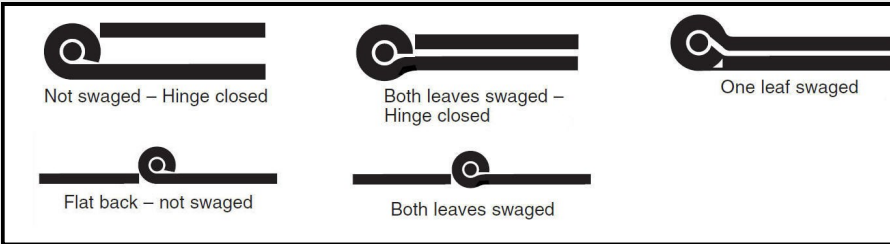

**PLAIN OR STANDARD ASSEMBLY** this is a surface-type hinge. The leaves lie flat

**SWAGING** the forming of one or both leaves toward or beyond the center of the pin, swaging slightly increases leaf width.

**BOTH LEAVES HALF-SWAGED** both leaves are swaged approximately one-half the pin diameter with a minimum clearance between leaves when parallel.

**ONE LEAF HALF-SWAGED** one leaf swaged one half the pin diameter.

**ONE LEAF FULL-SWAGED** one leaf swaged equal to the pin diameter and both leaves parallel when in a closed position.

**REVERSE SWAGED** one leaf swaged to simulate reverse assembly. Leaves will not close to a parallel position.

**OFFSET** forming one or both leaves away from the center of the pin. Offsetting slightly decreases leaf width.

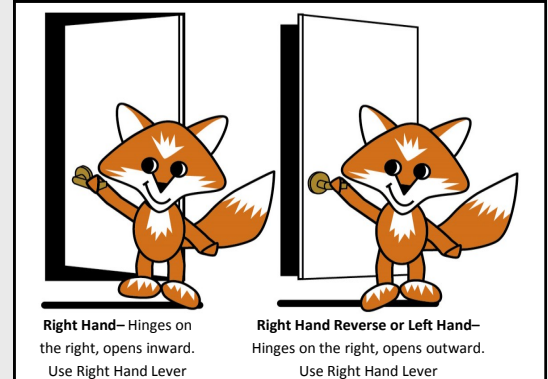
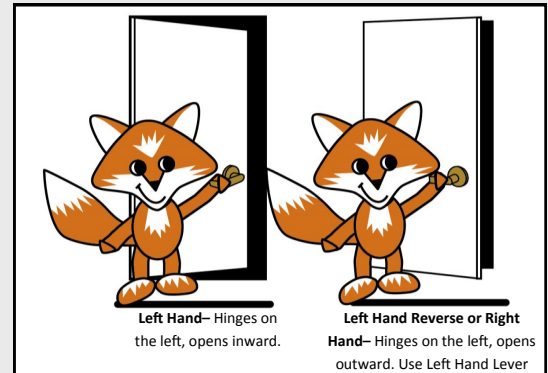

**GAUGE** the thickness of a hinge leaf.

**LEAF** the portion of a hinge extending laterally from the knuckle which usually revolves around a pin.

**HINGE LENGTH** the length of the leaves measured parallel to the pin.

**LEAF WIDTH** the dimension from the center of the pin to the outer edge of the leaf.

**HINGE WIDTH (same as open width)** the overall dimension of the leaves measured perpendicular to the pin.

**PIN** rod running the length of the hinge. The pin holds the leaves of the hinge together.

**KNUCKLE** the hollow circular part at the joint of a hinge through which a pin is passed. The knuckle is often called a loop, joint, node or curl.

**KNUCKLE LENGTH** the nominal or typical dimension of the knuckle measured parallel to the pin.

**PITCH** the dimension from a point on the knuckle to the same point on an adjacent knuckle on the same leaf.

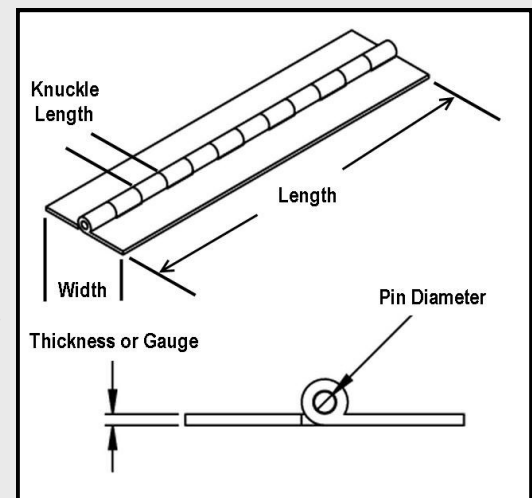

Information sources include Stanley Hardware



If you are still having difficulty choosing a hinge,  
please contact us at [askzoro@zoro.com](mailto:askzoro@zoro.com) or 855-289-9676

**Product Compliance and Suitability.**

THE PRODUCT STATEMENTS CONTAINED IN THIS EZTIP ARE INTENDED FOR GENERAL INFORMATIONAL PURPOSES ONLY. SUCH PRODUCT STATEMENTS DO NOT CONSTITUTE A PRODUCT RECOMMENDATION OR REPRESENTATION AS TO THE APPROPRIATENESS, ACCURACY, COMPLETENESS, CORRECTNESS OR CURRENTNESS OF THE INFORMATION PROVIDED. INFORMATION PROVIDED IN THIS EZTIP DOES NOT REPLACE THE USE BY YOU OF ANY MANUFACTURER INSTRUCTIONS, TECHNICAL PRODUCT MANUAL OR OTHER PROFESSIONAL RESOURCE OR ADVISER AVAILABLE TO YOU. ALWAYS READ, UNDERSTAND, AND FOLLOW ALL MANUFACTURER INSTRUCTIONS.